



ED series ECODRYER dryers
DEFINITIVE DRYING

ED260
ED340
ED460
ED660
ED900
ED1250



GIRBAU

ED series ECODRYER dryers

INTELLIGENCE WITH EFFICIENCY

ED1250

ED900



ED660

ED460



ED340

ED260



ED SERIES THE DEFINITIVE DRYERS FOR YOUR BUSINESS

IN DRYING THE BALANCE LIES IN THE PERFECT TRIANGLE

THE BEST DRYING:



Advanced, fast and **efficient** drying to save you time and money while caring for linen and for the environment.

PREMIUM PRODUCT

High-performance machines built for intensive use and **minimum maintenance**.

- MAXIMUM USABILITY
- MAXIMUM SAFETY
- MINIMUM MAINTENANCE
- PREMIUM PERFORMANCE

PREMIUM PERFORMANCE FOR PREMIUM DRYING



ADVANCED TEMPERATURE CONTROL

Temperature adjustment before and after the drum. Custom drying to suit the fabric, load and time.



PRECISION MOVEMENTS

Fitted with an inverter to control the speed and the mechanical action of the drum.



VARIABLE AIR FLOW*

Fitted with an inverter to adapt the air flow to the drying requirements and those of the installation.

*ED900 & ED1250 models



LATEST-GENERATION ADAPTABLE USER INTERFACE

Simple and intuitive for basic users or fully adjustable for advanced users, including up to 40 multi-phase programmes.



NO DRUM BEARING WHEELS

Absence of noise, less maintenance.



EFFICIENCY AND COMFORT

Thermal insulation of the unit and the door (double glass) for efficiency and comfort.



ADVANCED HUMIDITY SENSOR

Efficient programmes without over-drying fabrics.



DURABILITY

Stainless steel drum.



ADAPTABILITY

The door opening direction can be changed on the spot.

QUALITY TREATMENT OF THE FABRIC



Fluffy Towel Laundry **GIRBAU**

MINIMUM WEAR ON FABRIC

The **care drum** system used by Girbau on the drums in its washing machines has been transferred to its dryers.

Pressing out the holes in the drum, instead of drilling them out as other manufacturers do, makes all the difference in the treatment of the linen. The result - longer-lasting fabrics.

In turn, advanced rotation control cares for the linen throughout the drying cycle.



CARESSING YOUR SENSES

Stroking an article of linen, sensing its fragrance and its softness and fluffiness against the skin, transports us to a world of emotions that we associate with well-being.

A good drying process leads to a sensory and personal experience for your clients, making them view their business in a different and more pleasant way.

Drying is what gives your business its personal touch. How can you insist that the quality of your fabrics is important if you don't give them the pampering they deserve during the drying process?

We invite you to stamp more personality onto your business in an efficient and profitable way. Your clients deserve it, as does your business.

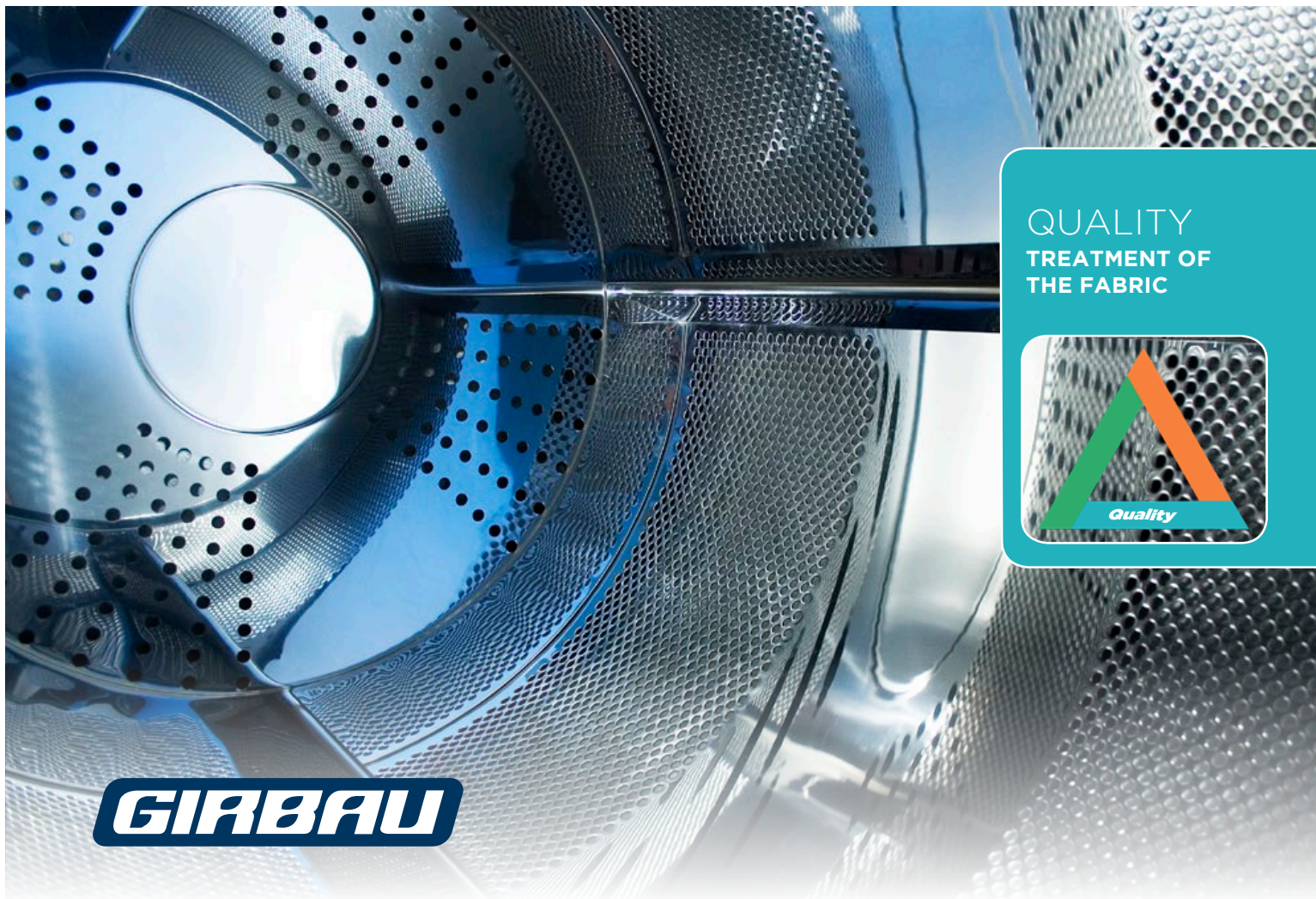

GIRBAU

QUALITY
TREATMENT OF
THE FABRIC



**DELICATE
TREATMENT**

To ensure the linen is treated gently, the holes in the drum (stainless steel AISI 430) are stamped out rather than drilled. This ensures that the fabric never comes into contact with the sharp edges left by perforated drums.

The absence of welds in the drum makes for a very strong structure while ensuring a gentle treatment for the linen.



GDRIVE

Girbau's exclusive control and communication system linking the inverter, motor and microprocessor ensures that the whole assembly is properly balanced and has a longer life.

GDrive can be used to control the rotation speed of the drum and the rotation intervals.



**SPEED
CONTROL**

This function controls the rotation speed of the drum using the GDrive system.

It can be activated in manual or automatic mode. In manual mode the rotation speed of the drum can be varied with the cycle activated, and the temperature and drying time can also be altered while the dryer is running.

In automatic mode, the rotation speed of the drum can be adjusted to suit the residual moisture content of the linen.

THE SUCCESS OF THE BEST PROCESS

Laundering is a process. A good wash is of little use if not followed by a thorough drying or a good ironing. Girbau has drawn on more than 50 years' experience in laundering to achieve a perfect match for your washers and ironers. Only if every part of the laundry process is based on efficiency, quality and reliability can a laundry become cost-effective and provide added value for your clients.

**EFFICIENCY
MINIMUM
CONSUMPTION
AND COSTS**



EFFICIENCY GUARANTEE



**THE POWER OF
CROSS FLOW**



**HEAT CAPTURE
TECHNOLOGY**

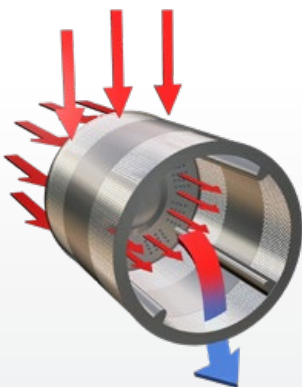

Directing the flow of air through the linen and making the most of their temperature are key factors in getting the best performance from a dryer.

The combination of a radial and an axial airflow allows air to penetrate between the garments, ensuring optimum drying in short cycle times.

The crossing of the two flows makes cross-drying possible. The air circulates through the linen in the middle of the drum.



The double glass and double panel door system ensures higher performance to take maximum advantage of heat energy.

There is no leakage of air or heat. The fact that the dryer is not giving off heat makes the work environment pleasant and safe.



**MOISTURE
CONTROL**

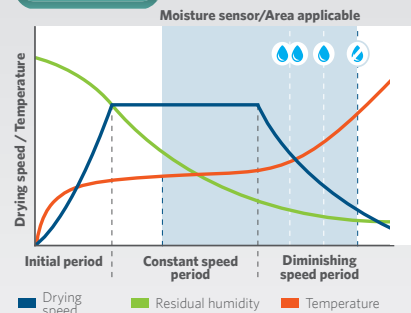

The residual moisture control system is highly accurate and reliable. Prevents the linen from overdrying and shortens the cycle time.

PERFORMANCE/ EFFICIENCY/ PRODUCTIVITY

The drying process consumes more energy than any other process in laundering.

Optimising energy use and achieving better results in less time are the key factors that make these dryers an essential ally in reducing running costs.



POWER RATING
SPEED OF DRYING



GIRBAU

WHEN SIMPLICITY MEANS RELIABILITY

SIMPLER, EASIER TO CONTROL AND MORE RELIABLE.

The ethos behind these dryers is that reliable solutions need not be complex.

The challenge is to achieve greater reliability with simplicity.

The heating system is one example of this. The reduced size of the burner assembly means that space can be optimised and more power achieved.

GAS-HEATED VERSION

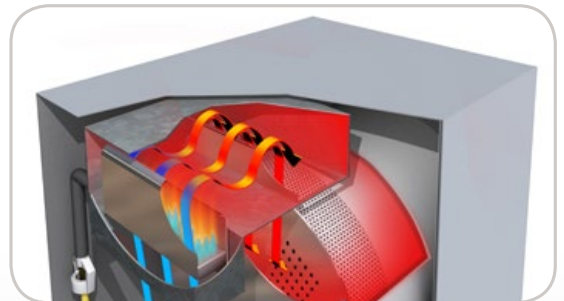

ELECTRICALLY-HEATED VERSION

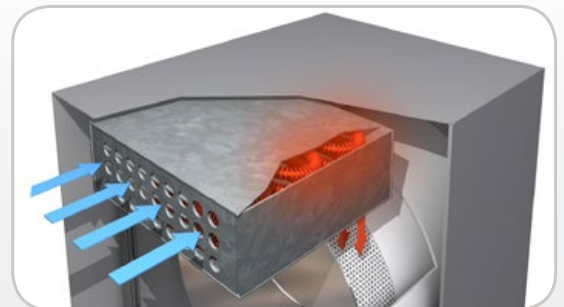

STEAM VERSION

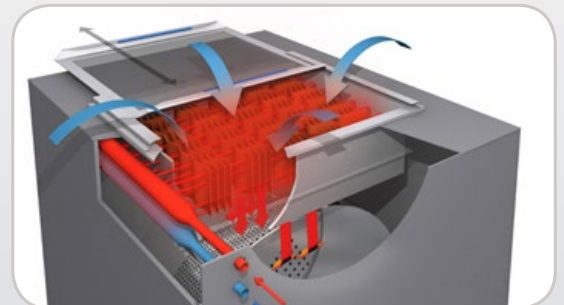

PREMIUM
PRODUCT



GIRBAU

MINIMUM MAINTENANCE

REDUCING MAINTENANCE MEANS GREATER EFFICIENCY

LARGE CAPACITY FILTER

The large capacity filter, the easy accessibility for cleaning and the angle of the filter (which helps to release fibrin), helps to save time on maintenance.



SPECIFIC FAN

The specially-designed fan with curved blades keeps maintenance to a minimum. The level of ventilation is maintained without reducing performance over time.



TOTAL ACCESSIBILITY

The total accessibility of the transmission system allows easy, quick maintenance. The toothed belt does not need retightening.



MAXIMUM SAFETY

SAFETY WITH THE COOL DOWN SYSTEM

After the program has ended, the system ensures that the dryer and the linen remain at a temperature below the safety temperature in order to prevent any incidents that might arise from the load being left inside.

FIRE PREVENTION SYSTEM

A system for extinguishing fires arising inside the dryer. It monitors all the temperature sensors, both while the program is running and at rest.

USABILITY

PROFESSIONAL CONTROL



The control panel reflects the ethos of Girbau's Inteli control, with a system that streamlines programming and operation. Operators find the system of icons easy to learn. Featuring 10 preset programmes and up to 40 user-specific programmes.

VERSATILITY

Control can be activated in the Pro version (multi-phase programs, and with the possibility of selecting different temperatures, working modes, drum rotation speeds and intensity and the mechanical intensity in each phase) or in the Easy Use version.

PRECISION

The display shows the status of the process at all times, informing the user of the time left, the function and the temperature.

ANTI-WRINKLE

If the linen is left inside the drum once the cycle has ended, the system activates the suction and rotates the drum to prevent the linen from creasing.

VENDED CONTROL



In the case of the Coin-op version, both the coin box and vending options work with 3 temperature programs: high, medium or low, and with a programmed time cycle. A modifiable program.



Coin box option: The dryer incorporates a coin box and can be operated directly by paying with coins on the machine itself. The electronic coin boxes can be programmed to accept different types of coins.



Vending option: The dryer can connect to a central payment unit (external start-up system).

PREMIUM PERFORMANCE



WET CLEANING READY

The perfect dryer for delicate fabrics and the most sophisticated processes. It incorporates a dual temperature sensor at the air flow inlet and outlet.

The versatility of the control makes it possible to adapt the drying cycle parameters to **Wet Cleaning** processes.

The user can set temperature variations for a particular length of time or even program different spin speeds in the same program.

SHAFT SUPPORT

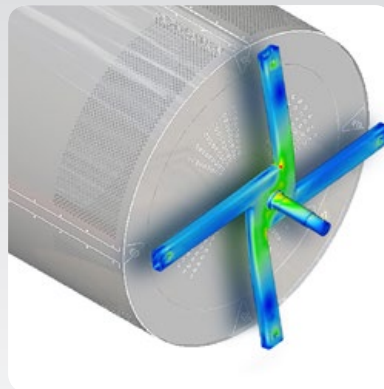

There is none of the wear or maintenance associated with support wheels.

At the same time, the **absence of wheels** means that the unit runs very quietly. The drive belt can be accessed easily.

ERGONOMIC DESIGN



The wide door makes loading and unloading easy.

The ergonomic design, with easy access and filter cleaning, contributes to operator comfort and increases their output.

ED1250

ED900

PREMIUM
PRODUCT



GIRBAU

HIGH CAPACITY COMES TO THE ED SERIES BIG. IN BOTH SIZE AND FEATURES

The new high-capacity spin dryers share the excellent performance of the other ED models, and incorporate innovative features to ensure best results.

OPTIONS FOR ALL

Heating systems available to suit all needs: gas, electric and steam.

ADAPTIVE AIR FLOW

The amount of air circulating around the load can be regulated thanks to the incorporation of a frequency inverter to control the fan. The air flow can be adjusted to meet the requirements of drying and of the installation.



GAS POWER CONTROL

Gas-heated high-capacity dryers feature instant power control built into the drum. This control, which is automatic and transparent to the user, makes the most efficient use of energy and assures drying quality.

ADVANCED STEAM HEATING

In the case of steam heating, an air redirection system is incorporated to allow cool air into the drum immediately. This avoids the heat lag effect in the heat battery and at the same time minimises energy use.

The new steel exchangers increase working capacity at fluid pressures of up to 15 bar.

ED series ECODRYER dryers



			ED260	ED340	ED460	ED660	ED900	ED1250	
Drum dimensions	Volume	lit (cu.ft)	260 (9,2)	340 (12)	460 (16,2)	660 (23,3)	900 (31,8)	1.250 (44,1)	
	Capacity 1/25 - 1/20	kg (lbs)	10,4 (22,9)-13 (28,7)	13,6(20)-17 (37,5)	18,4 (40,6)-23 50,7)	26,4 (58,2)-33 (72,8)	36 (79,4)-45 (99,2)	50 (110,2)-62,5(137,8)	
	Diameter	mm (in.)	736 (29)			940 (37)		1.250 (49,2)	
	Lenght	mm (in.)	612 (24,4)	800 (31,5)	663 (26,1)	950 (37,4)	733 (28,9)	1.022 (40,2)	
Machine dimen- sions	Width L	mm (in.)	798 (31,4)			1.002 (39,4)		1.370 (53,9)	
	Depth P	mm (in.)	985 (38,8)	1.173 (46,2)	1.056 (41,6)	1.343 (52,9)	1.585 (62,4)	1.874 (73,8)	
	Height H	mm (in.)	1.522 (59,9)			1.828 (72)		2.377 (93,6)	
	Height H (Steam)	mm (in.)	1.553 (61,1)			1.859 (73,2)		2.377 (93,6)	
	Door opening height	mm (in.)	570 (22,5)			695 (27,4)		776 (30,6)	
Weights	Net weight of the machine	kg (lbs)	249 (549)	279 (616)	339 (747)	386 (850)	732 (1615)	818 (1803)	
Dimensions of packaging	Width L	mm (in.)	826 (32,5)			1.030 (40,6)		1.429 (56,3)	
	Depth P	mm (in.)	1.092 (43)	1.280 (50,4)	1.163 (45,8)	1.450 (57,1)	1.651 (65)	1.940 (76,4)	
	Height H	mm (in.)	1.680 (66,1)			1.985 (78,1)		2.526 (99,4)	
Extraction	ø Steam extraction connection	mm (in.)	150 (5,9)			200 (7,9)		300 (11,8)	
Power capacity of motors	Power capacity of motors	kW	0,40	0,45	0,80	0,85	1,50		
	Power capacity of fan	kW	0,25			0,55		1,50	
Gas heating	Power (Hi)	kW(B.T.U./h)	18,6 (63.466)	21 (71.655)	31 (105.776)	36,4 (124.142)	72 (245.674)	98 (334.390)	
	Voltage		200-240/ 1ph/ 50-60 Hz.				200-480/ 3ph/ 50-60Hz.		
	Consumption	kWh/l	1,3	1,1			1,18	1,16	
	Drying time. Capacity 1/25	min.	25			22	23	19	
Electric heating	ER (Reduced power capacity)	kW	9,1	12,4	18,1	24,8	-	-	
	EN (Normal power capacity)	kW	12,4	18,1	24,8	31	49,2	67,2	
	Voltage		200-415/ 3ph / 50-60Hz				380-415/ 3ph/ 50-60H.		
	Consumption	kWh/l	1,1			1,43			
	Drying time. Capacity 1/25	min.	29	27			30		
Steam heating	Heating power	kW(B.T.U./h)	19,9	20,6	41,8	42,7	105,4	107,7	
	Voltage		200-240/ 1ph/ 50-60 Hz.				200-480/ 3ph/ 50-60Hz		
	Consumption	kWh/l	1,70			0,85	1	1,78	
	Drying time. Capacity 1/25	min.	24	27	23	29	32		

Data obtained from tests conducted in a laboratory in accordance with standard ISO 9398-2

GIRBAU S.A. reserves the right to change design and/or specification without notice





E&B

EASY & BEST SOLUTIONS

EASY AND SUSTAINABLE SOLUTIONS

We propose a new way of working, aimed at achieving the best solution in the easiest way possible

Just let us know your production requirements
We will take care of the rest.

Easy and best.



BRANCHES

- Argentina - Buenos Aires - Tel. +54-1 149017600 - girbauargentina@girbau.com
- Australia - Sydney - Tel. +61 2 96755860 - sales.australia@girbau.com
- Brazil - Sao Paulo - Tel. +55 11-29820446 - girbaudobrasil@girbau.com
- China - Shanghai & Hongkong - Tel. +86-21-5713 1103 - info.china@girbau.com
- Cuba - La Habana - Tel. (+53-7) 8662071 al 73 - girbau@girbau.co.cu
- Dominican Rep. - Punta Cana - Tel. +1 809-959-0615 - infodominicana@girbau.com
- France - Grésy sur Aix - Tel. +33 456 574 030 - infofrance@girbau.com
- Germany - Ratingen - Tel. +49 2102 9934619 - girbaugermany@girbau.com
- Italy - Marcon (VE) - Tel. +39 0418654330 - infoitaly@girbau.com
- Mexico - Cancún - T. +52 998 688 6336 - info.mexico@girbau.com
- Portugal - Porto - Tel. +351 22 3758909 - vendasportugal@girbau.com
- U.A.E. - Dubai - Tel. +971 4-8839951 - sales.gme@girbau.com
- U.K. - Hitchin - Tel. +44(0)-1462 427780 - info.uk@girbau.com
- U.S.A. - Oshkosh, Wi & Los Angeles, Ca - Tel. +1(920) 2318222 - info@cgilaundry.com

HEADQUARTERS

GIRBAU, S.A. Ctra de Manlleu, km. 1 - 08500 Vic (Barcelona) Spain - girbau.com
Tel. (+34) 93 886 2219 - sales@girbau.com



Watch video

